

PICTOR GO 620

KEY FEATURES

The Pictor GO 620 is an easy-to-mount, low-profile work light fit for many vehicles.

PRECISE - Twist and turn to suit your specific vehicle and get light exactly where you need it.

BUILT TO LAST - Long lifetime and high operational safety with minimum maintenance.

VERSATILE - Asymmetric flood light pattern suitable for different vehicles and areas of use.





TECHNICAL SPECIFICATIONS	PICTOR GO 620
Theoretical / Operational Lumens:	3000lm / 2000lm
Color Temperature:	5000K
Nominal / Input Voltage DC:	12V, 24V / 9–16V, 18–32V
Power Consumption:	29W
Nominal Current:	2.16A@12V / 1.03A@24V
Mount:	Single Bolt M8
Connector:	Built-in Deutsch DT-2 (2-pin)
EMC:	CISPR 25 Class 5, EN12895, ISO 13766, ISO 14982, ISO 7637-2
Electronics:	Isolated
Shock:	60G
Vibration:	8Grms 24–2000Hz
Lens:	Plastic
Body:	Aluminum
IP Rating:	IP68, IP6K9K
Weight:	0.55 kg
Salt mist:	ISO 9227 240 h
Operating Temperatures:	-40°C... +85°C (Overheat protected)

DRAWINGS

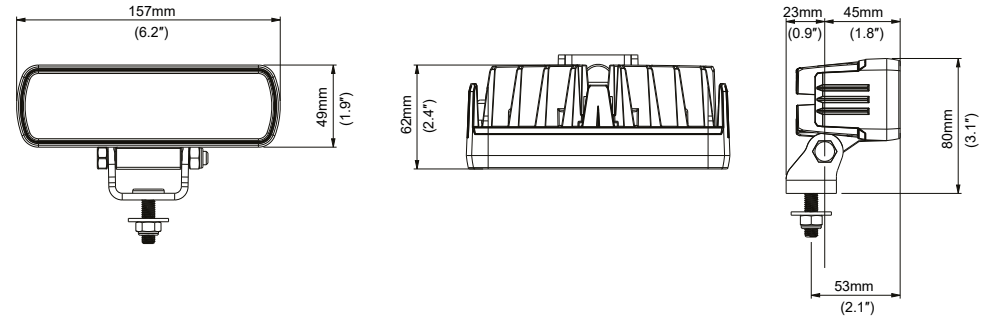

LIGHT PATTERNS

Pictor GO 620, 2000lm Flood

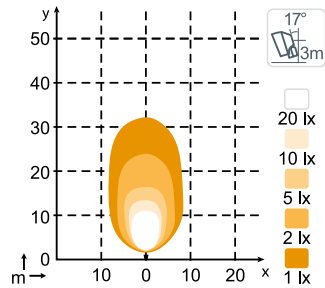

Pictor GO 620, 1800lm Diffused

